



Guilloché

OLIVARI ➤

2016

Guilloché
gioielli
per la casa
jewelry
for the house

OLIVARI 

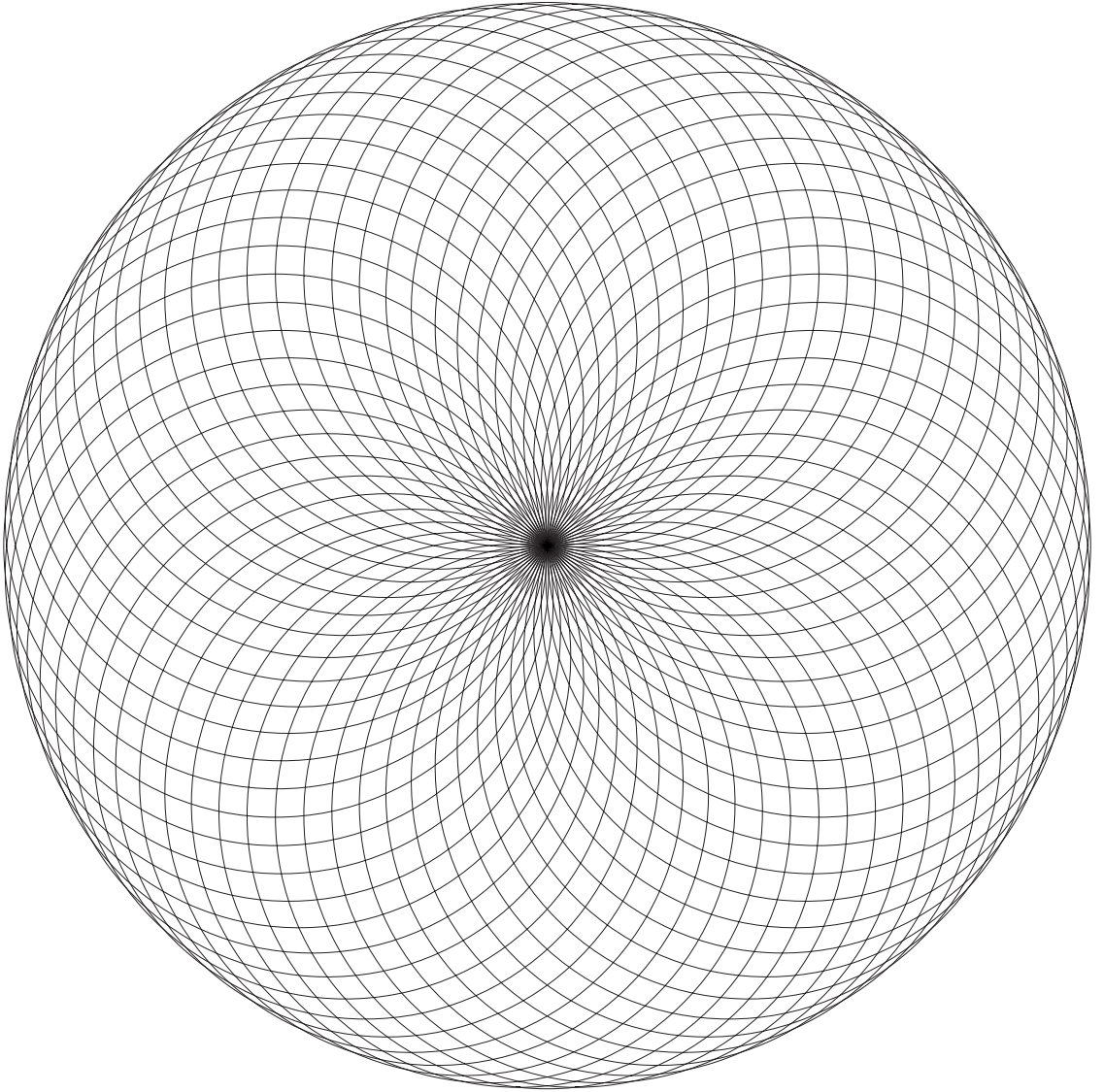

Per la prima volta,
e direi con piacere, ci siamo dedicati alla
sola superficie, alla sua valorizzazione, quando abitualmente la nostra è una ricerca sui volumi, sulle loro rispettive proporzioni, sulla finitura estetica e prestazionale delle superfici, ma non appunto sulla loro caratterizzazione. Il decoro che ci è sembrato più interessante e più in sintonia con il nostro modo di intendere il design è stato il *guilloché*, per la sua capacità di rendere direi 'viva' la superficie, per mezzo dell'interazione del segno geometrico con la luce, una sorta di vibrazione che si percepisce spostando il punto di vista, come si fa nell'atto di avvicinarsi e afferrare la maniglia. Approfondendo gli aspetti tecnologici di questa particolare decorazione abbiamo scoperto un mondo parallelo a quello nostro tipicamente industriale, quello dell'alto artigianato, della lavorazione ancora manuale che utilizza macchine affascinanti del secolo scorso e che richiede all'operatore un'esperienza e una sensibilità molto elevate, che si affinano negli anni. Da qui è seguita una lunga ricerca per raggiungere una padronanza (anche tecnica) dell'incisione *guilloché*, che ha richiesto tempo e dedizione per essere reinventata e trasferita all'interno di un ciclo di lavorazione integrato. La serie di maniglie *Diana* e *Atena*, e i decori *Damier*, *Barley*, *Chevron*, *Rank*, *Ligne e Panier* ne sono il frutto. Partire dalla storia, da quella dei motivi decorativi a quella delle tecniche di produzione, ci ha portato a questo risultato, che ci piace pensare aperto a nuovi sviluppi.

For the first time, and I would say with pleasure, we have focused exclusively on the surface, on its enhancement, whereas our norm is to concentrate our attention on the volumes, on their respective proportions, on the aesthetics and performance of the surface finishes, but not, as mentioned, on their characterisation. The decoration that we thought was most interesting and most in line with our way of understanding design was *guilloché* engraving because of its ability to bring a surface to 'life' due to the interaction of geometrical signs with light: a kind of vibration that is perceived when the point of view shifts, as indeed occurs when approaching and grasping a handle. Further exploring the technological aspects of this particular decoration, we discovered a world parallel to our own typically industrial realm: that of the top level artisan, where work is still done by hand using fascinating machines from last century that require the operator to be highly experienced and very sensitive, attributes refined through years of practice. This initial contact was followed by a lengthy period of research to reach a mastery (also technical) of guilloche engraving, which required time and dedication to be reinvented and transferred within an integrated production cycle. The *Diana* and *Athena* series of handles, as well as the decorations *Damier*, *Barley*, *Chevron*, *Rank*, *Ligne and Panier* are the fruits of our research. Starting from history, from that of decorative motifs to that of production techniques, has led us to this result, which, we like to think, is open to new developments.

Antonio Olivari

Il *guilloché* è una tecnica decorativa di incisione realizzata con apposite macchine che, guidate manualmente, generano un preciso, intricato e ripetitivo pattern sul materiale di base. A differenza dell'incisione *tout court*, realizzata a mano, che si presta a un decoro più libero e naturalistico, quella realizzata con le macchine *à guilocher* è tipicamente meccanica e ripetitiva, consente però di ottenere un'infinità di pattern differenti al variare dei parametri di lavorazione combinandosi alla sensibilità tecnica, ma anche estetica, dell'operatore. L'origine esatta delle prime macchine non è nota con certezza. È possibile che abbiano paternità svizzera, forse per opera di un ingegnere francese di nome *Guillot*. I primi esempi di casse di orologio lavorate con questa tecnica portano inciso l'anno 1624. L'effettiva introduzione nel settore dell'orologeria risale al 1786, quando Abraham-Louis Breguet inizia a utilizzarli per decorare i quadranti e le casse dei suoi orologi. Questa tecnica sperimenta una straordinaria popolarità nel XIX secolo, grazie soprattutto all'opera di Peter Carl Fabergé.

Guilloché is a decorative engraving technique done with special machines that, guided manually, generate a precise, intricate and repetitive pattern on the base material.

Unlike simple engraving, done by hand, which lends itself to freer and more naturalistic motifs, ones made with guilocher machines are typically mechanical and repetitive. This allows, however, for an infinite number of different patterns by varying the processing parameters, which work in concert with the operator's technical, but also aesthetic, sensitivities.

The exact origin of the first machines is not known with certainty. Its ancestry can possibly be traced back to Switzerland, perhaps to a French engineer named *Guillot*.

The earliest examples of watch cases bearing motifs done with this technique are engraved with the year 1624. Its actual introduction into the watch industry dates back to 1786 when Abraham-Louis Breguet began using it to decorate the dials and cases of his watches. The technique experienced an extraordinary popularity in the nineteenth century, thanks largely to the work of Peter Carl Fabergé.



atena
ligne







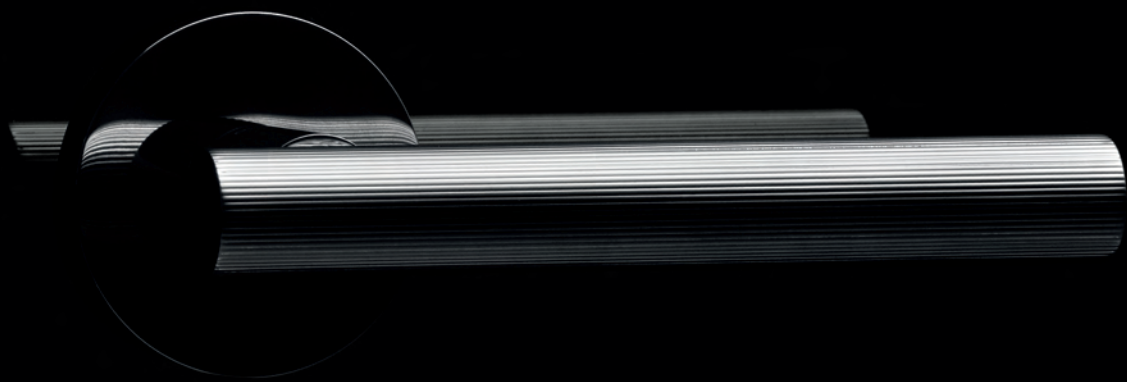

atena
rank









atena
panier



papier

Frankfurter
ZEITUNG

HERAUSGEGEBEN VON

Frankenkaras harte Hand







diana
barley

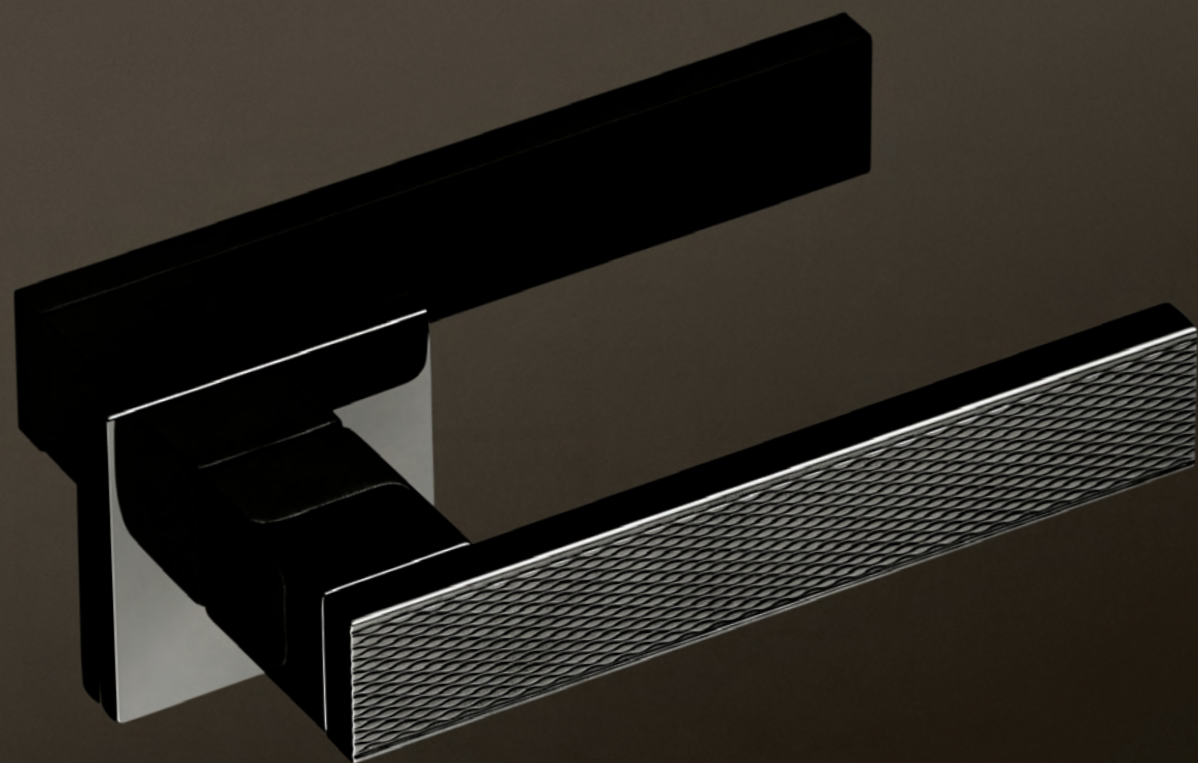



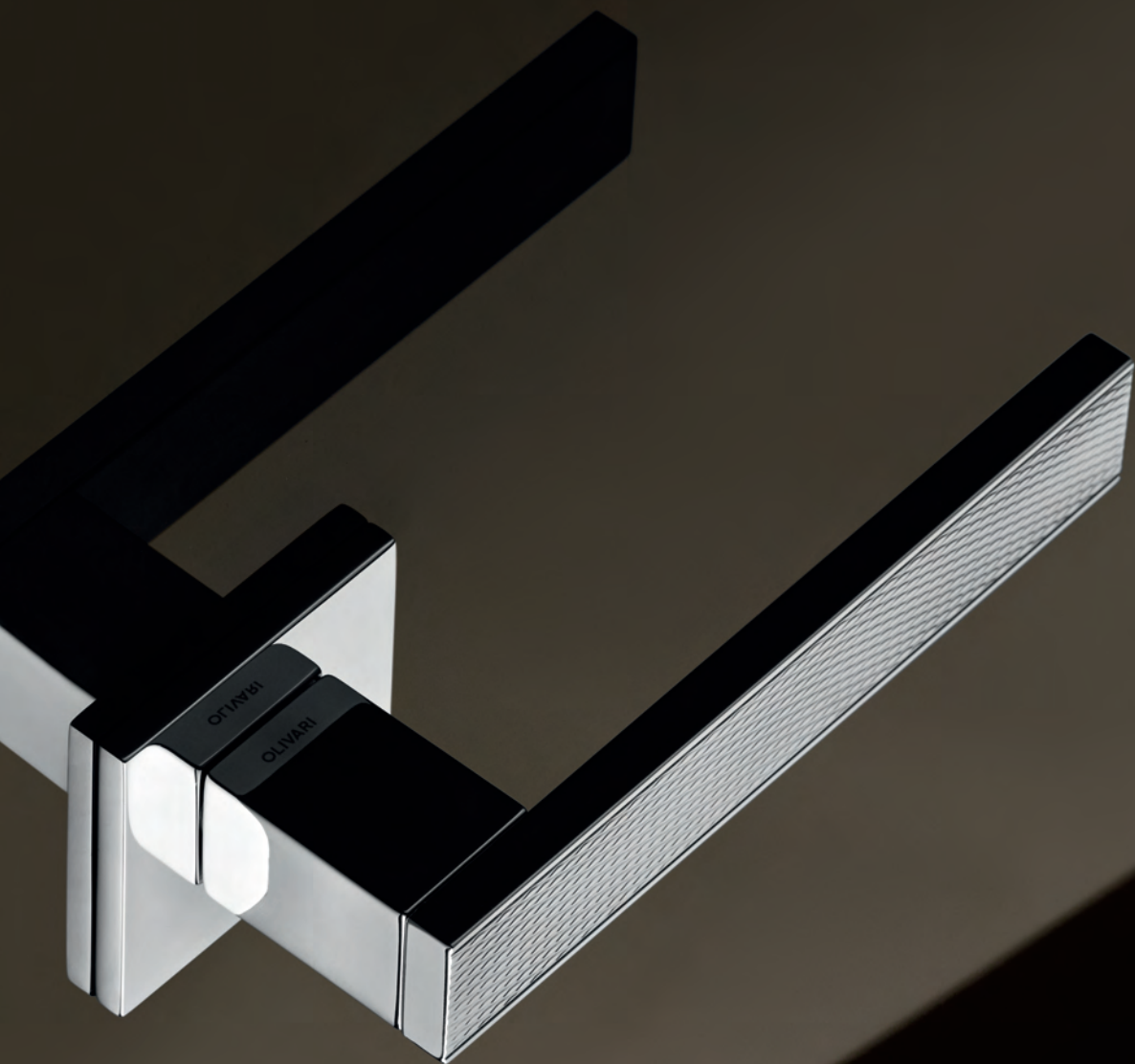

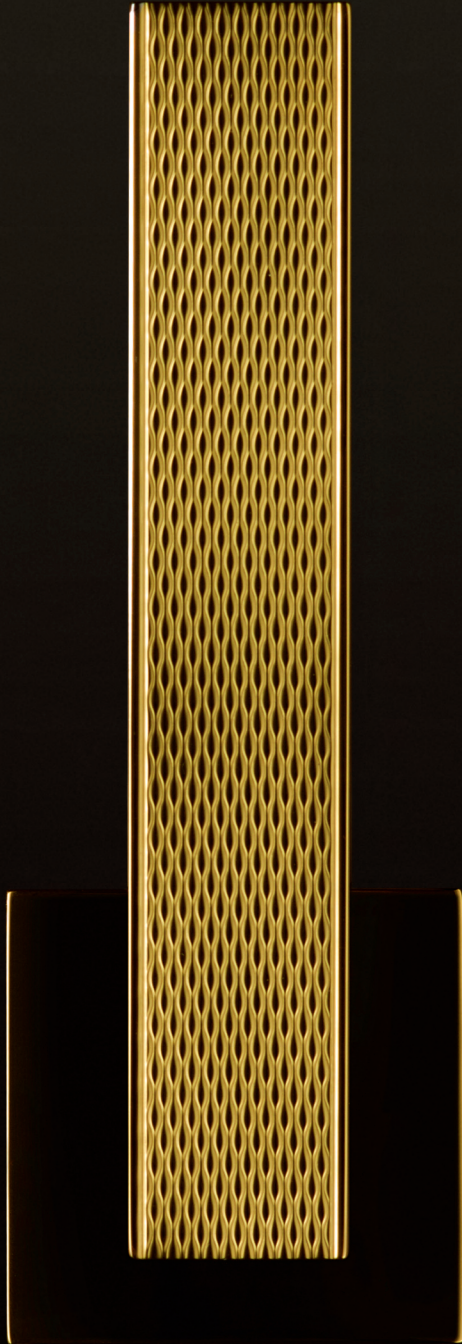

diana damier





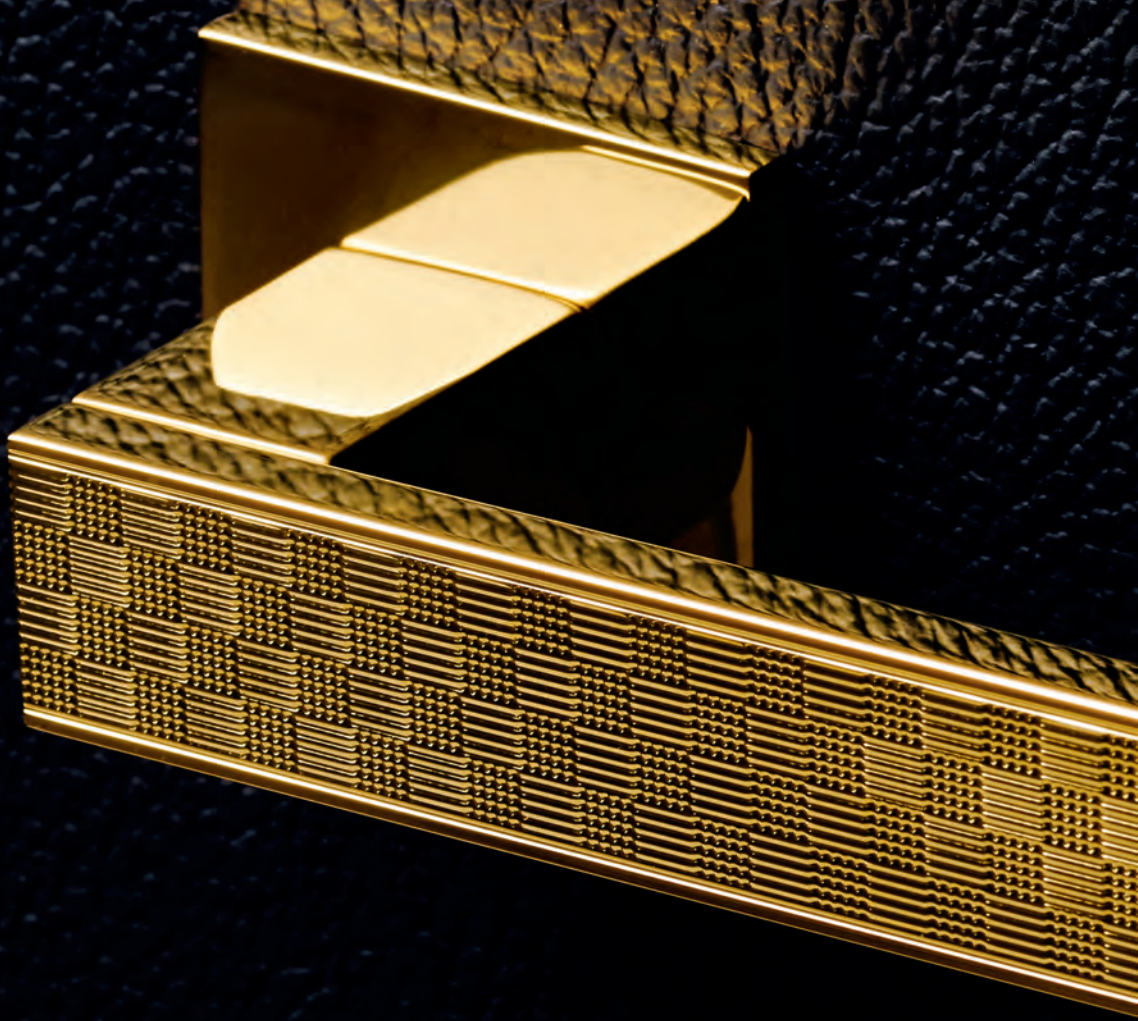

diana
chevron

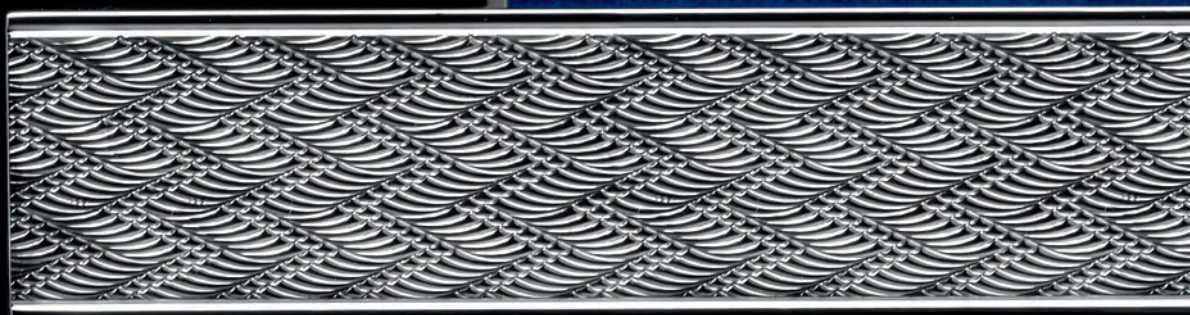



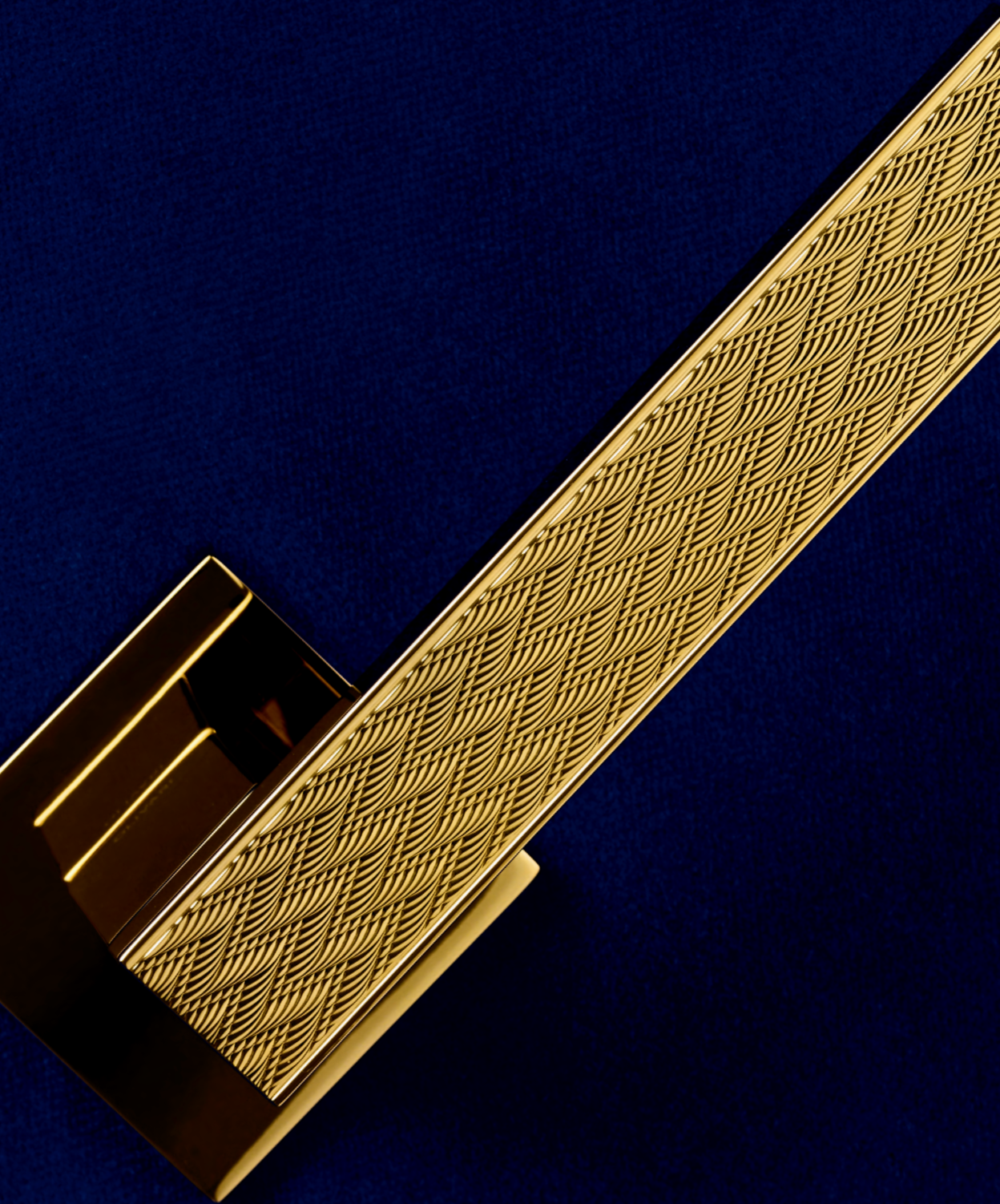

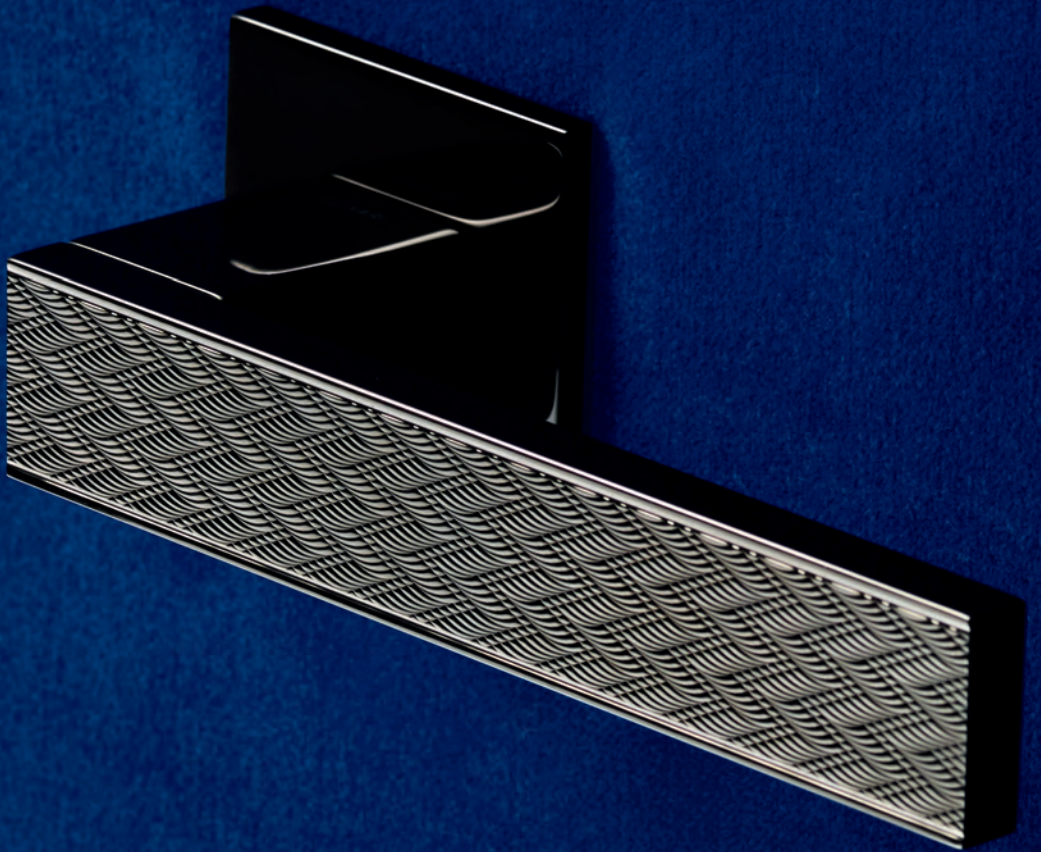

atena ligne

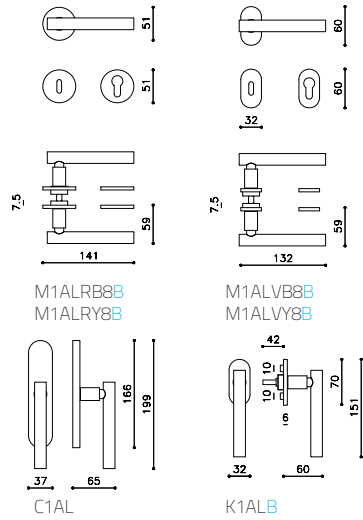
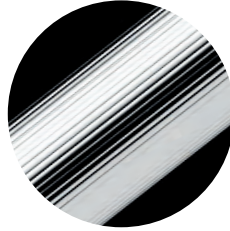

M1ALRB8B
M1ALRY8B

M1ALVB8B
M1ALVY8B

C1AL

K1ALB

ottone/brass



CR cromato/chrome



ZL superoro lucido/supergold bright

atena rank

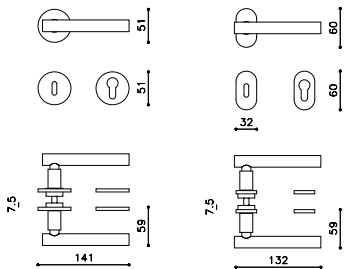

M1ARRB8B
M1ARRY8B

M1ARVB8B
M1ARVY8B

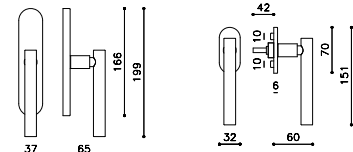

C1AR

K1ARB



CR cromato/chrome



ZL superoro lucido/supergold bright

atena panier

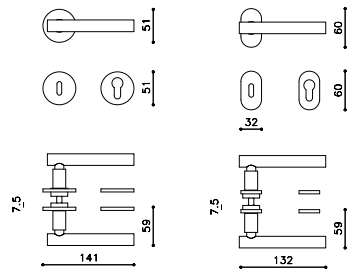
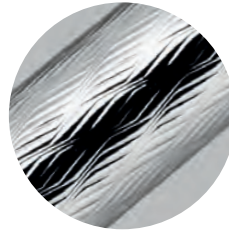

M1APRB8B
M1APRY8B

M1APVB8B
M1APVY8B

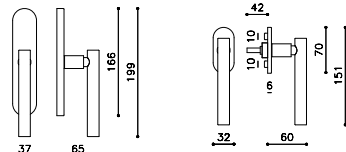

C1AP

K1APB



CR cromato/chrome



ZL superoro lucido/supergold bright

diana barley

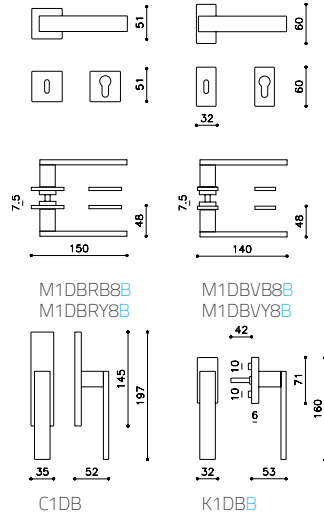
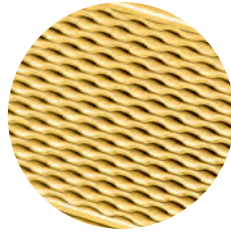

ottone/brass



CR cromato/chrome



ZL superoro lucido/supergold bright

diana damier

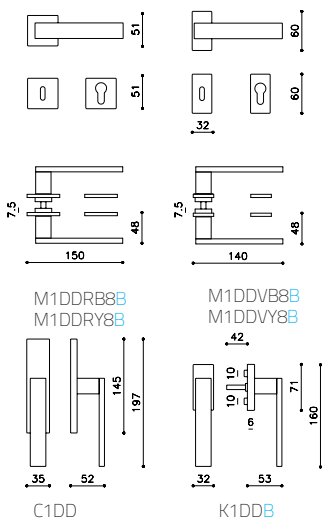
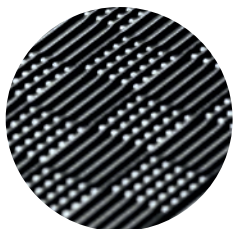

ottone/brass



CR cromato/chrome



ZL superoro lucido/supergold bright

diana chevron

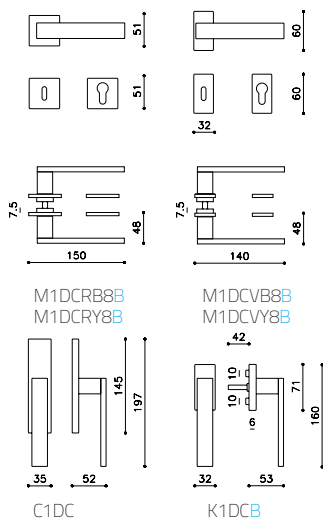

ottone/brass



CR cromato/chrome



ZL superoro lucido/supergold bright

Concept and Graphic

Marco Strina

Text

Francesca Picchi

Photo

BHM studio

Translation

C. L. L. Murray

Press Office

Clara Buoncristiani

Pre press

Up studio_Milano

Printed in Italy

Galli Thierry_Milano 2016

Thanks to

Alejandro Espinosa Caballero

Cuoium srl

Betti Sperandeo

Olivari B. spa

Via Giacomo Matteotti, 140
28021 Borgomanero NO Italy

T +39 0322 835080

F +39 0322 846484

olivari@olivari.it

www.olivari.it





olivari.it