

2023

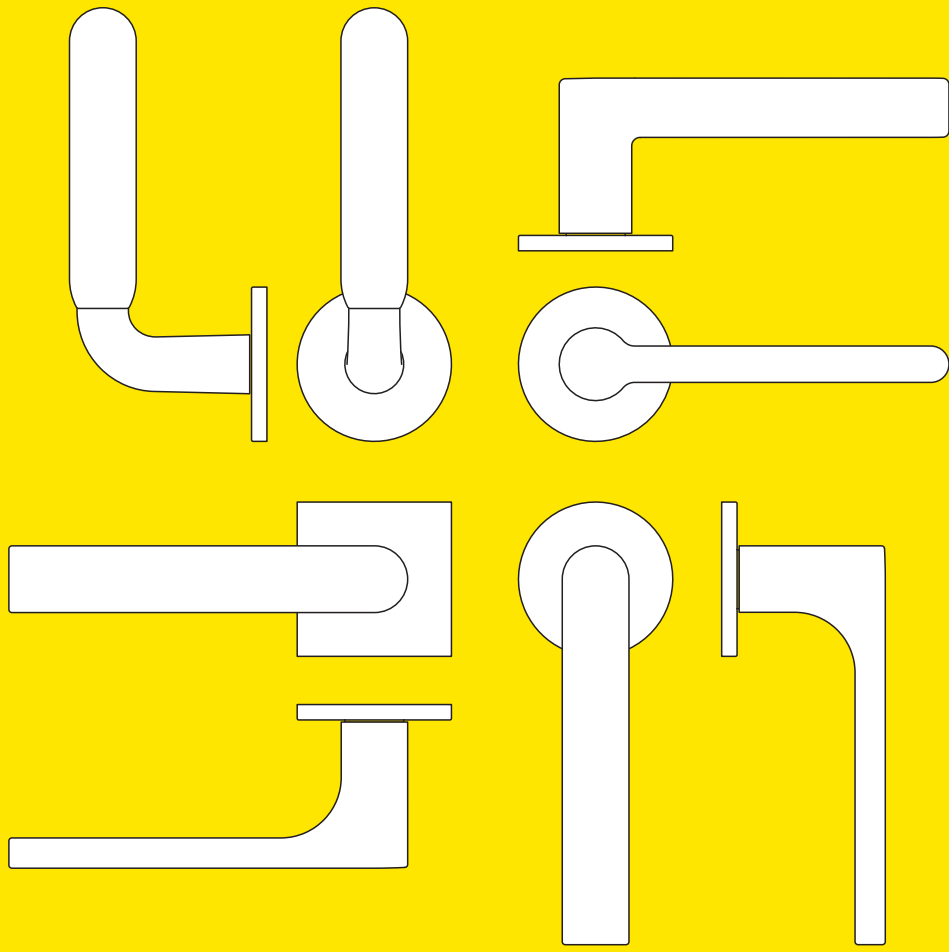

**OLIVARI** 

Dal 1911 Olivari realizza maniglie in Italia,  
all'interno dei propri stabilimenti,  
dove si svolge l'intero ciclo produttivo.  
Partendo da barre in ottone, le maniglie vengono  
stampate, lavorate, smerigliate, lucidate,  
croMatte e marchiate al laser.  
Olivari ha ottenuto le certificazioni  
ISO 9001 e ISO 14001  
e si avvale delle tecnologie più evolute,  
ma ha mantenuto tutta la sapienza artigianale  
accumulata in 110 anni di storia.

Since 1911 Olivari has been manufacturing handles  
at its own factories in Italy  
where the entire production process takes place.  
Starting with brass billets, the handles are forged, milled,  
polished, buffed, chrome-plated and hallmarked with a laser.  
Olivari has attained ISO 9001  
and ISO 14001 certifications.  
Though it uses the most advanced technology,  
Olivari preserves all the artisanal wisdom  
it has accumulated in 110 years of history.

**OLIVARI** 

Kai Linke  
James e Marialaura Irvine  
Studio Olivari

# Alba Kai Linke 2023

M267B



CD Cromo lucido/bianco  
Bright chrome/white



ZD SuperOro lucido/bianco  
SuperGold satin/white



DD SuperBronzo satinato/bianco  
SuperBronze satin/white



MD Cromo satinato/bianco  
Satin chrome/white



TD SuperOro satinato/bianco  
SuperGold satin/white



UD SuperAntracite satinato/bianco  
SuperAnthraccite satin/white

C267

K267B

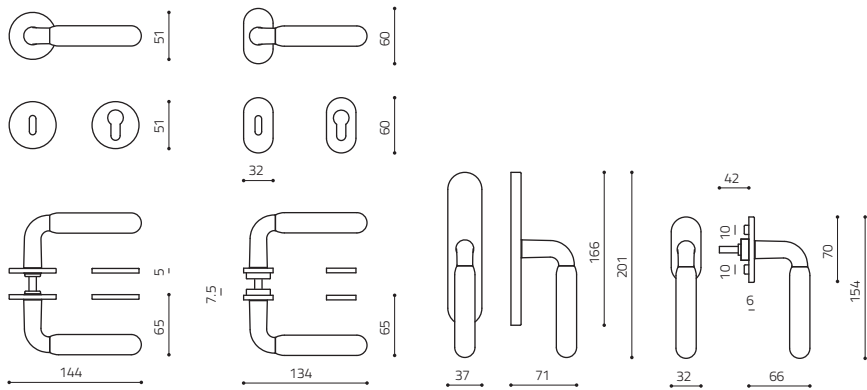

M267RB8B  
M267RY8B

M267VB8B  
M267VY8B

C267

K267B

*Per il design preciso e minimalista di Alba mi sono ispirato alla maniglia storica in porcellana. Il mio intento era quello di utilizzare metallo e porcellana in una sorta di continuità formale. La sezione rotonda è il motivo unificante, ma ho voluto dare all'impugnatura in porcellana una leggera sovradimensione a favore dell'ergonomia. KL*

*I was inspired by the historic porcelain handle for the precise and minimalist design of Alba. My intent was to use metal and porcelain in a sort of formal continuity. The round section is the unifying motif but I wanted to give the porcelain handle a slight oversize in favour of ergonomics. KL*

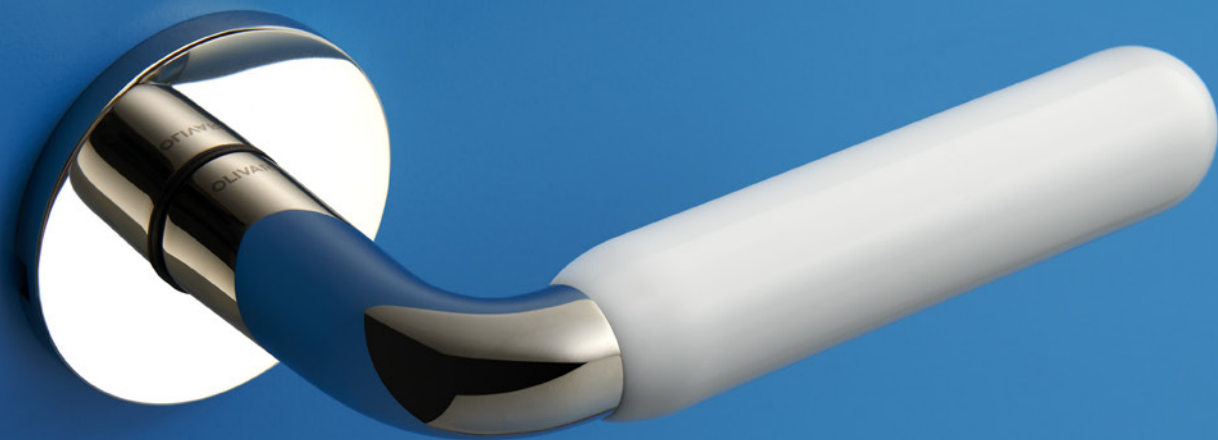







a



b



c





## Kai Linke

1980 in Offenbach a.M./Germany

*Kai Linke apre lo Studio KL nel 2009 a Francoforte. I suoi progetti fanno parte di numerose pubblicazioni, mostre e collezioni internazionali e hanno ricevuto numerosi premi. Ha studiato Product Design presso l'Università di Arte e Design HfG Offenbach e ha lavorato per lo Studio Makkink & Bey, Tobias Rehberger e Tomas Saraceno.*

*Ha ottenuto una borsa di studio dalla Fondazione accademica nazionale tedesca nel 2005-2009, dall'Akademie Schloss Solitude di Stoccarda nel 2014-2016 e dal Goethe Institute Villa Kamogawa a Kyoto/Giappone nel 2018. Nel 2019 ha pubblicato il libro "Kai Linke in Japan".*

*Nel 2021 ha progettato e concettualizzato il padiglione tedesco "Spoon Archaeology" alla London Design Biennale insieme a Peter Eckart.*

*Kai Linke founded the Studio in Frankfurt in 2009. His projects are part of numerous international publications, exhibitions and collections and have been awarded several times. He studied Product Design at HfG Offenbach University of Art and Design and worked for Studio Makkink & Bey, Tobias Rehberger and Tomas Saraceno. He was granted a scholarship from the German National Academic Foundation in 2005-2009, the Akademie Schloss Solitude in Stuttgart in 2014-2016 and at Goethe Institute Villa Kamogawa in Kyoto/Japan 2018. 2019 he published the book "Kai Linke in Japan". 2021 he designed and conceptualised the German pavilion "Spoon Archaeology" at the London Design Biennale together with Peter Eckart.*

a\_ Clique, 2018, Bronze, produced by Pulpo

b\_ Cosmo, a light object in between lampion and jewel, handmade by a workshop for handicapped people in Germany.

c\_ Spoon Archaeology, 2022, exhibition, Staatliche Kunstsammlungen Dresden

# Logo L James e Marialaura Irvine 2023

M198B



CR Cromo lucido/Bright chrome



IS SuperInox satinato/  
SuperStainlessSteel satin



US SuperAntracite satinato/  
SuperAntracite satin



CO Cromo satinato/Satin chrome



DS SuperBronzo satinato/  
SuperBronze satin



NP Nero opaco/Matt black

C198

K198B

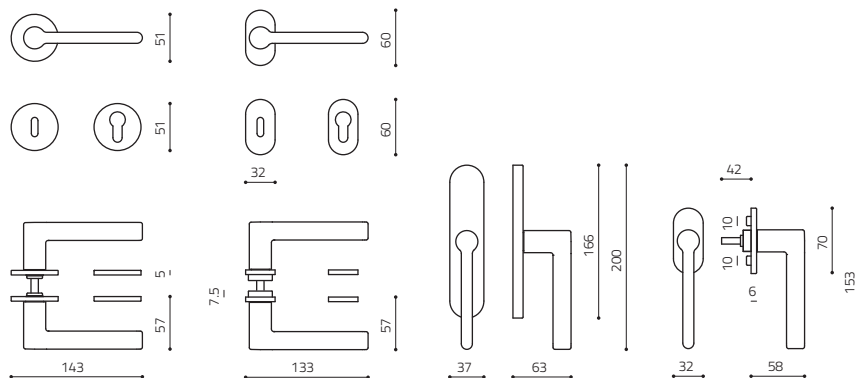

M198RB8B  
M198RY8B

M198VB8B  
M198VY8B

C198

K198B

*James disegnò Logo nel 2006. Un prodotto iconico che nella sua semplicità rappresenta ciò che io definisco "Metodo Irvine"; un metodo universale fatto di passione per il dettaglio, funzionalità ed ironia. Riproporzionare il suo design rispetto alla nuova rosetta, è stato per me naturale: un gesto etico che guarda al prodotto come oggetto universale, senza tempo e fuori dalle mode del momento, proprio come il DNA di Olivari. Marialaura Rossiello Irvine*

*James designed the model Logo in 2006. An iconic product that in its simplicity represents what I call the "Irvine Method"; a universal method made of passion for details, functionality and irony. Reproportioning his design with respect to the new rosette was natural for me: an ethical gesture that looks at the product as a universal object, timeless and unfashionable, just like Olivari's DNA. Marialaura Rossiello Irvine*









a



b



c

# James e Marialaura Irvine

London 1958 - 2013, Napoli 1972



*Lo studio è stato fondato nel 1988 da James Irvine e nel corso dei suoi 30 anni di storia ha tessuto una fitta rete di relazioni interattive tra le “fabbriche del design”: artigiani, grafici, curatori, giornalisti, fotografi, designer e imprenditori. Il Metodo Irvine è guidato dalla curiosità, dall’amore per il dettaglio e da una grande dose di umorismo, combinando un rigoroso approccio britannico con la stratificazione della tradizione storica tipica dell’architettura italiana. Studio Irvine è la storia di uno studio familiare in continua evoluzione.*

*The studio was founded in 1988 by James Irvine and throughout its 30 year history, it has woven a dense network of interactive relations among “fabbriche del design”: artisans, graphic designers, curators, journalists, photographers, designers and entrepreneurs. Metodo Irvine is driven by curiosity, love for detail and a great deal of humour, combining a rigorous British approach with the layering of historical tradition typical of Italian architecture. Studio Irvine is the story of a constant evolving family studio.*

a \_ W82,2008, Wasterberg  
b \_ Mimmo, 2010, Marsotto  
c \_ Juno 2012-2022, Arper

# Gloria

Studio Olivari 2023

M268B



CR Cromo lucido/Bright chrome



TS SuperOro satinato/  
SuperGold satin



IS SuperInox satinato/  
SuperStainlessSteel satin



US SuperAntracite satinato/  
SuperAnthracite satin



CO Cromo satinato/Satin chrome



NL SuperNichel lucido/  
SuperNickel bright



RS SuperRame satinato/  
SuperCopper satin



NP Nero opaco/Matt black



ZL SuperOro lucido/  
SuperGold bright



NS SuperNichel satinato/  
SuperNickel satin



DS SuperBronzo satinato/  
SuperBronze satin



BP Bianco opaco/Matt white

C268

K268B

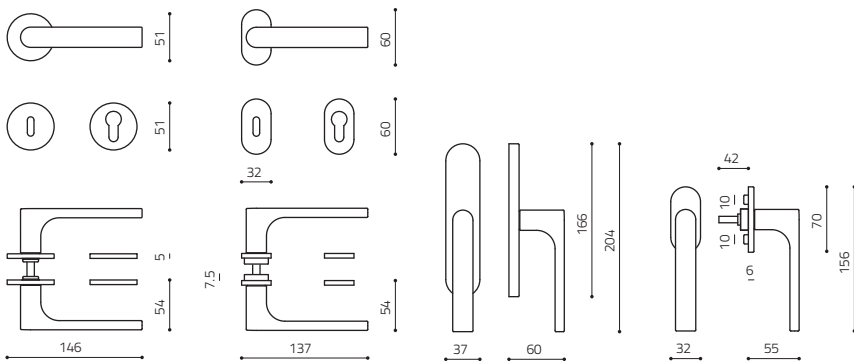

M268RB8B  
M268RY8B

M268VB8B  
M268VY8B

C268

K268B

*Gloria nasce dalla ricercare una forma adattabile alla molteplicità dei contesti e quindi la scelta di ammorbidire la forma eliminando presenze geometriche marcate, mantenendo comunque una regolarità del disegno. La maniglia si sviluppa con linee tonde dal mozzo fino alla parte di raccordo con la leva, mentre termina con linee più geometriche all'estremità della leva.*

*The principle from which Gloria comes from is that of seeking a design adaptable to the multiplicity of contexts and therefore the choice to soften the form by eliminating strong geometric presences, while maintaining a regularity of the design. The handle develops with rounded lines from the hub to the lever, while it terminates with more geometric lines at the end of the lever.*



# Gloria Q Studio Olivari 2023

M269B



**CR** Cromo lucido/Bright chrome



**TS** SuperOro satinato/  
SuperGold satin



**IS** SuperInox satinato/  
SuperStainlessSteel satin



**US** SuperAntracite satinato/  
SuperAnthracite satin



**CO** Cromo satinato/Satin chrome



**NL** SuperNichel lucido/  
SuperNickel bright



**RS** SuperRame satinato/  
SuperCopper satin



**NP** Nero opaco/Matt black



**ZL** SuperOro lucido/  
SuperGold bright



**NS** SuperNichel satinato/  
SuperNickel satin



**DS** SuperBronzo satinato/  
SuperBronze satin



**BP** Bianco opaco/Matt white

C269

K269B

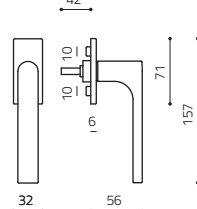
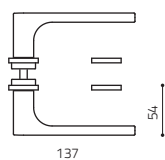
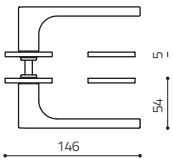
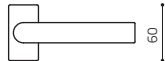
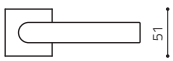

M269RB8B  
M269RY8B

M269VB8B  
M269VY8B

C269

K269B









Il catalogo è soggetto ad aggiornamenti.

Ci riserviamo di apportare qualsiasi modifica ai prodotti e di eliminarli dalla produzione, senza obbligo di preavviso. Dati, misure o schemi hanno solamente carattere informativo e non sono vincolanti.

Eventuali errori e/o refusi di stampa non costituiscono motivo di contestazione.

Modelli e marchi depositati. Tutti i diritti riservati © OLIVARI B. s.p.a.

I prodotti OLIVARI sono tutelati da brevetto in Europa e in molti paesi extra UE.

Al fine di evitare contraffazioni, marchiamo al laser tutte le maniglie sia con il logo OLIVARI sulla leva che con il codice identificativo del lotto e la data di produzione sul collarino. Questa marcatura indelebile, certifica che il prodotto è realizzato in ambito ISO 9001 e ne consente la tracciabilità. Invitiamo i clienti a diffidare da prodotti "tipo OLIVARI" e ad acquistare solo prodotti originali "OLIVARI".

We reserve the right to modify and discontinue any products, without prior notice. Data sheets, measurements or patterns are only for information and are not binding. Any misprints do not allow raise objections. Registered trademarks and patented designs. All rights reserved © Olivari B. s.p.a.

OLIVARI products are registered and patented in Europe and many countries extra UE.

In order to avoid counterfeits, we laser-mark all the door handles both with the OLIVARI logo on the lever and with the identification code of the lot and the date of production on the neck. This indelible marking, certifies that the product is made in ISO 9001 and allows traceability. We invite customers to beware of "OLIVARI type" products and to buy only "OLIVARI" original products.

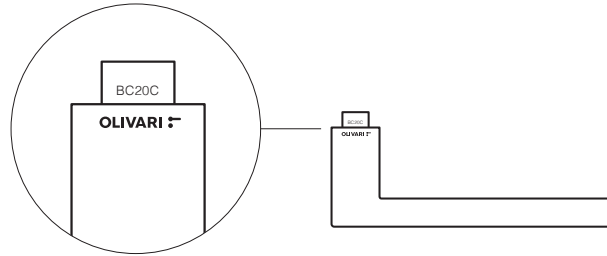

Questo catalogo è stato stampato su carta Sappi Magno Satin certificata FSC, prodotta con cellulosa proveniente da foreste gestite in maniera sostenibile per l'ambiente. L'energia necessaria per la stampa è stata prodotta da un impianto fotovoltaico. Il contributo all'ambiente è il seguente: CO<sup>2</sup> non immessa in atmosfera 79.645 kg/year, petrolio risparmiato 42.063 l/year, alberi equivalenti 159 trees/year.

This catalog was printed on paper Sappi Magno Satin FSC certified, produced with cellulose from forests managed in a sustainable way for the environment. The energy for printing was totally produced by a photovoltaic system. The contribution to the environment is the following: CO<sup>2</sup> not released into the atmosphere 79.645 kg / year, oil saved 42.063 l / year, trees equivalent 159 trees / year.

## Concept and graphics

Marco Strina

## Photo

Laura Fantacuzzi e Max Galati Forcaude  
Leo Torri

## Pre press

Up studio\_Milano

## Printed in Italy

Galli Thierry\_Milano 2023

## Olivari B. spa

Via Giacomo Matteotti, 140  
28021 Borgomanero NO Italy  
T +39 0322 835080  
F +39 0322 846484  
olivari@olivari.it  
www.olivari.it





olivari.it



olivariofficial



olivariofficial



olivari\_maniglie



olivari channel